

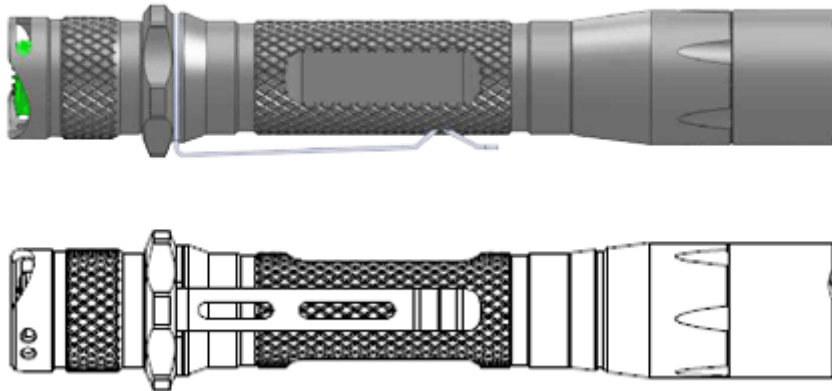

---

Lumapower Multi-purpose Lighting Tool

# Vantage



Ideal lighting tool to match with different fields of usage

---

## User Manual



The exclamation point within an equilateral triangle is intended to alert the user to the presence of important operating and maintenance instruction in the literature

## Welcome to Lumapower

Please take a moment to register your product on our Web site at <http://www.Lumapower.com>. It enables us to keep you posted on our latest advancements, and helps us to better understand our customers and build products that meet their needs and Expectations. This product has been designed and manufactured to the highest quality standards. However, if something does go wrong with this product, Lumapower and its national distributors warrant free of charge labour and replacement parts in any country served by an official distributor.

**Unpacking:** Check the product carefully. If it has been damaged in transit, report the damage immediately by calling your dealer and/or the shipping company that delivered it.

**Read Instructions.** All the safety and operating instructions should be read before the product is operated.

**Follow Instructions.** All operating and use instructions should be followed.

**Replacement Parts.** When replacement parts are required, be sure the replacement parts have the same characteristics as the original part. Unauthorized substitutions may cause damage to the unit.

## Introduction

Lumapower VANTAGE supports input voltage from 0.9V to 4.2V. It is powered by 2 x AA cell (Alkaline, NiMH),. VANTAGE is fitted with pure white / warm white LED module driven by current regulation circuitry to achieve a consistent level of light output for the useable life of the batteries. **Never use rechargeable Li-ion batteries, it may damage your flashlight.**

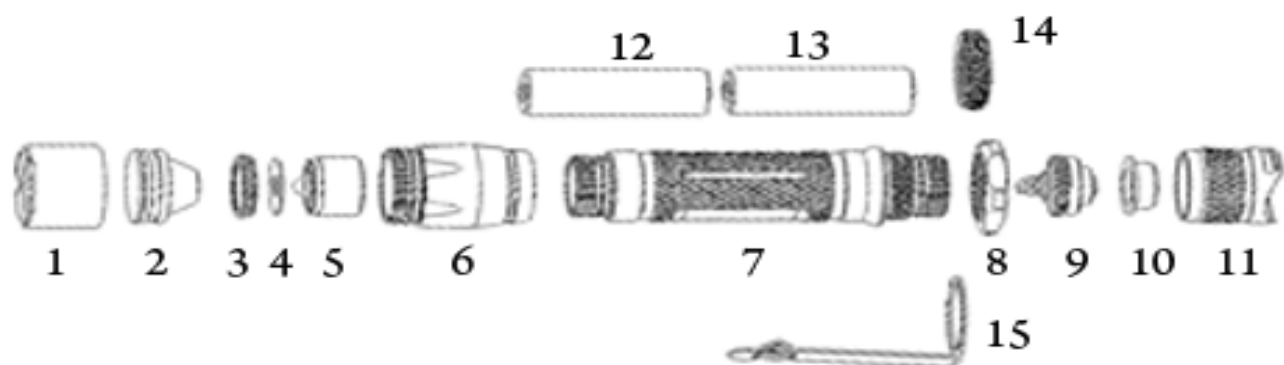

1-5. (Front retainer , lens , reflector, LED module)

6. Top housing

7. Battery tube

8. Anti-roll retainer ring, 14 pocket clip retainer, 15 pocket clip

9. switch module , 10. Rubber cap, 11. Tail switch housing

12, 13. Battery

VANTAGE features a forward clicky switch and multi-level digital output control circuit with memory functions.

Half-press the tail switch to power on VANTAGE momentary, full press to lock it for constant on. Another full press to release the lock (power off). As Vantage designed with **Thread-Lock system**, loose the tail switch by half turn will avoid the flashlight from power-on.

### **Digital output control**

Half press to cycle the output from Low, Medium and High.

At each output level, with a full press to lock it.

You can change the output by power off and on (within 1 second). As the powered on over 1 second will remains the same output with your next start.

**Tactical Lock** – Select the desired level and remains the power on for 1 second, then 4 half-press within another 1 second to lock the selected level. Further power on will always remains the same output until Unlock.

**Unlock** – 4 half-press within 1 second

### **Battery Installation**

Unscrew the tail switch housing and insert new batteries with positive ends towards LED assembly. Replace tail switch and hand tighten. Depress tailcap pushbutton switch to test.

**Note:** It would not light if battery is inserted in wrong direction.

**VANTAGE with digital polarity protection design.**



**CAUTION:** VANTAGE tool-light are high-output lighting devices. Due to possible eye injury, **DO NOT look directly into the reflector when the light is switched on.** Safety is your responsibility, too.

External surface temperature will rise during prolonged operation; this is a normal operating phenomenon.

### **Battery Replacement**

If there is significant decrease in brightness of light output you should replace the battery. Unscrew the LED-engine and remove the old battery. Insert a new battery as mentioned in

### **Battery Installation Guide**



**WARNING:** Do not place loose batteries in a pocket, purse or other container containing metal objects or store with hazardous or combustible materials. Store in cool, dry, ventilated area. Follow applicable laws and regulations for disposal.

### **Maintenance**

Clean and lubricate threads with a clean cloth and apply thin coat of silicon-based lubricant to rubber O-rings. **Note:** Do not use petroleum-based lubrication on O-rings. After prolonged exposure to moisture, the bezel and batteries should be removed, inspected, and dried if necessary.



**WARNING:** Lumapower reflector is made with high precision process. Do not touch or clean the reflecting surface using any cloth which may cause damage to the surface material affecting the illuminating performance.



Reflecting surface

### **Non-use Periods.**

If VANTAGE is left unused for long period, the installed battery should be removed from the unit.

### **Output & Runtime**

Accurately specifying light output (lumens) and runtime is complicated for LED flashlights. Installed batteries and operating temperature are the main factors affecting the light output and runtime. Lumapower doesn't guarantee its products can reach the specification under the using condition of users.

### **Specification**

LED : Cree XR-E (R2-WC/WD, Q3-5A/5C)

Reflector : OP textured type

Output : 10 Lumens to 200 Lumens (max. with R2) with 2 x AA-size battery

Runtime : 90 minutes at High, 220 minutes at Medium (2XAA @ 2500mAh)

Batteries : Primary AA-Cell / rechargeable NiMH

Body coating : Type III HA Grey (optional Type III HA Silver)

Standard Dimension

- Overall length : 155mm
- Head Diameter : 25.4mm
- Body Diameter : 21.5mm
- Tail Diameter : 23mm
- Weight : 96g (without battery)

Accessories : spare o-rings, switch cap, pocket clip, clip-retainer

**Specifications:** All product specifications/features are subject to change without notification.